

NO  
TE  
BO  
OK

# Installation guide for wood cladding & panelling

sivalbp<sup>®</sup>  
bois, technologie & design



# OUR INSTALLATION TIPS

A practical guide to cladding & panelling

Architect : Archi 5 & Encore Hélieux Architectes  
Photographer : Sergio Grazia



## WHO IS THIS GUIDE FOR?

This guide is intended for tradespeople, construction companies, project managers and professionals seeking comprehensive guidance on the correct installation of Sivalbp cladding and panelling, in accordance with the relevant technical standards (DTUs) and the specific characteristics of our profiles.

# CLADDING

# INSTALLATION GUIDE



Architect : Archi5  
Photographer : Sergio Grazia

# THE 12 ESSENTIALS

## FOR SUCCESSFUL IMPLEMENTATION

This document does not replace the recommendations of french code of practice DTU 41.2

- 1 Do you have enough boards ?  
Allow for a wastage rate (on average 12-18%).
- 2 Transport and store in a dry, sheltered place, in a well-ventilated stack off the ground.
- 3 Install on 27 mm thick battens with a maximum centre-to-centre distance of 65 cm.
- 4 Ventilation is essential: air inlets and outlets must be fitted with rodent-proof grids.
- 5 Ensure a minimum ground clearance of 20 cm.
- 6 Handle the boards with care.
- 7 Fix using:
  - Stainless steel fluted or twisted nails, or stainless steel screws (minimum grade A2 – A4 for coastal areas).
  - 1 fixing for boards ≤ 125 mm: refer to the Sivalbp profile diagrams.
  - 2 fixings for boards > 125 mm: refer to the Sivalbp profile diagrams.
- 8 Limit the penetration of the fixing head to a maximum of 1 mm.
- 9 You must touch up all cuts using our touch-up finish.
- 10 Set up a protective barrier to protect the facades from splashes (weather, metal splashes, etc.).
- 11 For vertical installation:
  - the ends of the boards must be cut at an angle
  - double battens are required
  - the tongue at the end must face upwards
  - leave a gap (minimum 15 mm) between the boards and the floorboards, window frames, etc.
- 12 Please note: once the boards are laid, they are considered accepted

This document does not replace the guidelines set out in DTU 41.2. Find out more about our installation recommendations for our Ecothermo solutions in our product data sheets.

## INSTALLATION DIAGRAM FOR CLADDING RECOMMENDED BY SIVALBP

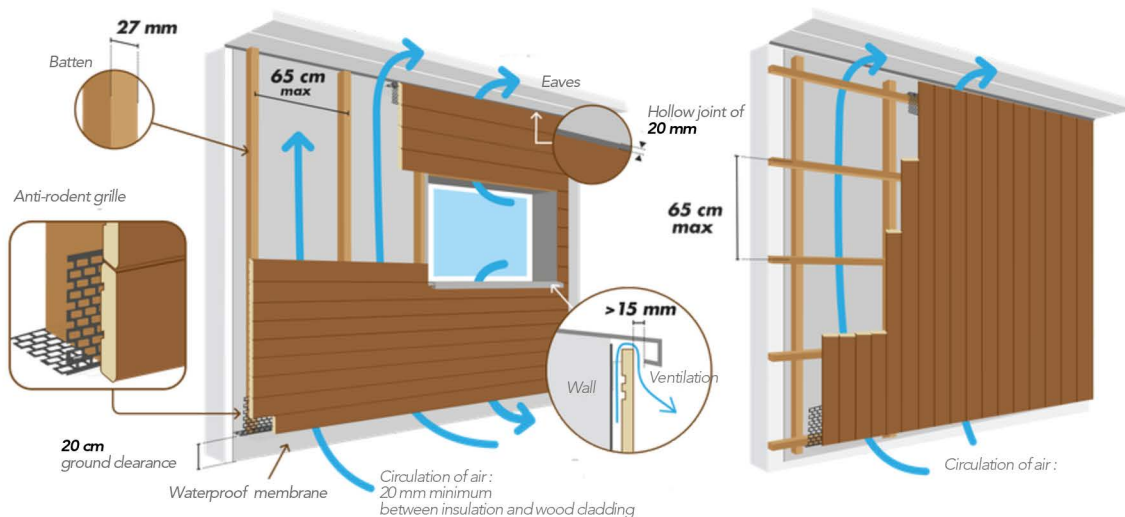

Horizontal installation

Vertical installation : mandatory double battening



To ensure proper installation, the guidelines set out in DTU 41.2 for external timber cladding must be followed.

## Exterior cladding made from solid wood or finger-jointed wood

They serve several purposes:

- A functional role: continuous protection against the elements.
- A thermal role: the thickness of the board, the wood itself and the air gap effectively improve the structure's thermal insulation.
- A mechanical role: resistance to impact and damage.
- The choice of finish, substrate, technical specifications and the quality of the installation are crucial.
- An aesthetic role: providing the finishing touch to your project.

## The different methods of installing wood cladding

- Horizontal installation: this is the most common method. Thanks to the vanishing lines, it creates the illusion that the building is taller. Sivalbp boards are grooved at the ends to ensure perfect joints. Sivalbp profiles, with concealed fixings, provide stability to the boards and ensure the finish lasts.
- Vertical installation: this is the most traditional method. It gives the building a slender appearance. The tongue must be positioned facing the prevailing wind. The bottoms of the boards must be chamfered to facilitate water drainage.
- Diagonal installation: this is the most original method. It lends a dynamic quality to the façade elements. It requires considerable skill during installation and particular attention to the cuts.
- Open-joint installation: this is the most difficult method but lends a certain lightness to the structure. It requires meticulous execution, given that the open joint necessitates a more durable, UV-resistant rain screen.

## Areas of use

- Detached or terraced houses, urban developments, industrial buildings and engineering structures.
- Exterior cladding for solid concrete walls, hollow concrete blocks, brick, exterior render or timber frames.
- New builds and extensions.
- Renovation of the building's appearance: cladding or replacement of the façade.

## Estimated area

Measure the frontage and add 12 to 18% to take into account cuts (gables, corners, openings, etc.).

## Preparation of the wood

- In order to 'acclimatise' the timber, the boards must be removed from their packaging 24 to 48 hours before installation. They must be stored on site in a sheltered area, in a well-ventilated stack, off the ground and protected from splashes.
- At the time of installation, the maximum moisture content of the boards must be 19%. In addition to this general rule, this moisture content must always be adjusted to suit the climatic conditions of the region in question. Ideally, timber should be used whose moisture content is as close as possible to the site's equilibrium moisture content. To achieve this, the installer must allow the cladding boards to stabilise before installation.

## The rain screen

The rain screen is a protective membrane designed to withstand rain and wind. Its use is mandatory (except on walls that are already waterproof, such as solid concrete walls).

It is fixed in place during the installation of the secondary framework and the fitting of the battens.

## The air gap

The ventilated air gap is a mandatory space behind the cladding boards. It is created by battens arranged vertically or horizontally in a staggered pattern.

This gap allows air to circulate and any moisture to be drawn away. This gap must comply with the following parameters:

- Ventilation inlets and outlets of 50 cm<sup>2</sup>/linear metre or more.  
Thickness in the main section of 20 mm or more. The battens must not obstruct air circulation;
- Air inlets must be located at the top and bottom of the cladding;
- The top and bottom ventilation outlets must ensure ventilation towards the outside and not towards the inside of the building in order to properly ventilate the cladding;
- Incorporate top and bottom rodent-proof ventilation grilles to allow for a ventilation cross-section.

## Preparing the substrate: the secondary framework

The secondary framework is the support to which the cladding boards will be fixed. It acts as an intermediate layer between the load-bearing structure and the cladding. The quality of the framework is essential for extending the lifespan of the cladding. A secondary framework consists of battens fixed to the building's load-bearing structure. These CLASS 2-treated battens have very specific dimensions to ensure the strength of the structure and the effectiveness of the air gap:

- Width of 30 mm or more
- Minimum thickness of 27 mm

They must be fixed with a minimum spacing of 40 cm and a maximum of 65 cm.

Fixing is carried out using stainless steel nails or twisted or ringed stainless steel screws, penetrating at least 30 mm into the studs.

The arrangement of the battens depends on the type of installation chosen:

- Horizontal installation: single vertical battens
- Vertical installation: double battens for better ventilation.



## Fixing cladding boards

- The boards are fixed to the battens using nails or stainless steel screws.
- For boards less than 125 mm (clear width), a single fixing is required (concealed fixing).
- For boards greater than 125 mm (clear width), two fixings are required (visible fixings).

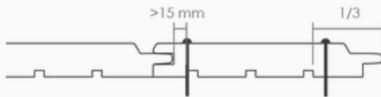
## TONGUE-AND-GROOVE PROFILES

PROFILES EFFECTIVE LENGTHS < OR = 125MM	PROFILES EFFECTIVE LENGTHS > 125MM
<b>SECRET NAIL</b>	<b>VISIBLE NAIL</b>
<p>1 single nail in the tongue : <b>secret fixing</b></p> 	<p>2 visible fixings:</p> <ul style="list-style-type: none"> <li>• 1 fixing at the top of the board</li> <li>• 1 fixing at the bottom of the board</li> </ul> 

## OPENWORK PROFILES

OPENWORK PROFILES	THICKNESS AND WIDTH 18x65 et 27x70
<p><b>PARALLÉLO 30</b> horizontal or vertical installation</p>	<p>1 fixing point in the centre of the panel + two fixings at each end</p>  <p>With a maximum centre-to-centre distance of 400 mm 2 fixings if the centre-to-centre distance is between 40 and 65 cm</p>
<p><b>TRAPÉZO</b> vertical installation</p>	<p>1 fixing point in the centre of the panel + two fixings at each end</p>  <p>With a maximum centre-to-centre distance of 400 mm 2 fixings if the centre-to-centre distance is between 40 and 65 cm</p>

## SPECIFIC INSTALLATION REQUIREMENTS FOR OUR CLADDING

- The head of the nails or screws must not penetrate further than 1 mm into the boards.
- Cut edges must be treated: preservation then finish. We also recommend that the ends of the boards should also be treated.
- The thickness of the battens used for the secondary framework must be a minimum of 27mm.
- For curved surfaces, the bending radius must be greater than 7m.
- A waterproof membrane satisfying the standard must be installed (unless the wall is made of shuttered concrete).

## PROTECTION AGAINST EXTERNAL FACTORS

### A few tips to optimise the durability of your cladding :

- Ensure there is sufficient ground clearance: the first board must be installed at a distance of at least 200mm from the finished external ground level.
- Direction of the boards: the tongue must always be placed at the top for horizontal installations, or towards the dominant winds when installed vertically.
- The cladding must not be in direct contact with other materials.
- The nearest plants must be kept away from the cladding.
- You are advised to cover the ground with gravel to allow rainwater to drain away quickly.
- The ends and any cuts must be treated with the same finish.
- Where surfaces join (corners, window surrounds, etc.) specific measures must be taken to ensure rainwater drains away to the outside of the frontage.

THE +

## OF SIVALBP FIXINGS

### The "1 Fix" - Certificates of compliance with French Code of practice DTU 41.2 - FCBA

COLLECTION	WOOD SPECIE	THICKNESS X WIDTH FACE COVER	BOARD	PROFILE	1 SECRET FIXING	
AUTHENTIC ÉLÉGANCE NEW AGE	Western Red Cedar	18 X 130	Planed Solid Wood Sanded solid wood Brushed Solid Wood	CHANFRÉA	FCBA Report N° 2014.216.120 of 30.04.2014	
ÉLÉGANCE NEW AGE	Larch A Choice	27 X 125	Brushed Solid Wood	SOLÉA II AFFINÉA	FCBA Report N° 2012.508.1347.2 of 12.12.2012	
AUTHENTIC ÉLÉGANCE NEW AGE	Douglas	21 X 125 27 X 125	Planed Solid Wood Sanded solid wood Brushed Solid Wood	LINÉA SOLÉA II AFFINÉA TABACOA II	FCBA Report N° 2012.508.1347.2 of 12.12.2012	
ÉLÉGANCE NEW AGE	Nordic Spruce	27 X 125	Brushed Solid Wood	SOLÉA II	DTU 41.2	
ÉLÉGANCE NEW AGE VINTAGE	Ecothermo Nordic Pine	20 X 125 27 X 125	Brushed Solid Wood	LINÉA SOLÉA II	FCBA Report N° 2012.508.1347.2 of 12.12.2012	

ECOTHERMO NORDIC PINE - SOLÉA II PROFILE

# TONGUES-AND- GROOVE PROFILES (grooved ends)

## CHANFRÉA



Chanfréa Profile available in 18x130

Installation according to FCBA certificate of compliance  
FCBA Report N°2014.216.120

## CHANFRÉA ÉVO



Chanfréa Evo profile en 20x150

Installation according to DTU 41.2

## LINÉA



Linéa profile available in 20x125 and 21x125

Installation according to FCBA certificate of compliance  
FCBA Report N°2012.508.1347.2

## LINÉA ÉVO



Linéa Évo profile available in : 18x182 - 20x130 - 20x150 and 21x157

Installation according to DTU 41.2

## SOLÉA II



Soléa II profile available in 27x125  
Profile compatible with the Affinéa profile

Installation according to FCBA certificate of compliance  
FCBA Report N°2012.508.1347.2

## AFFINÉA

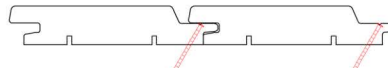

Affinéa profile available in 27x125  
Profile compatible with the Soléa II profile

Installation according to FCBA certificate of compliance  
FCBA Report N°2012.508.1347.2

## TABACOA II



Tabacoa II profile available in 27x125

Vertical installation only  
Installation according to DTU 41.2

## MICRO 2



Micro 2 profile available in 18x180 - 20x155 - 20x175 and 20x185

Installation according to DTU 41.2

## CLAVÉA



Clavéa profile available in 21x125

Installation according to DTU 41.2

# OPENWORK PROFILES

## PARALLÉLO 30



Parallélo 30 profile available in 20x65 and 27x70

Installation in accordance with DTU 41.2  
A bevel cut is required for vertical installation  
Double fixings at the ends

## CARRELET

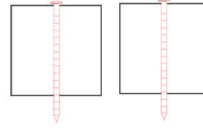

Carrelet profile available in 43x43

Installation in accordance with DTU 41.2  
Vertical installation only  
A bevel cut is required for vertical installation  
Double fixings at the ends

## TRAPÉZO

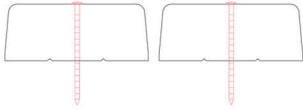

Trapézo profile available in 18x65 - 20x65 - 27x70 and 20x140

Installation in accordance with DTU 41.2  
Vertical installation only  
A bevel cut is required for vertical installation  
Double fixings at the ends



Architect - MO / CoCo Architecture -  
Photographer / Edouard Decam

# ACCESSORIES FOR CLADDING

## CORNER TRIM

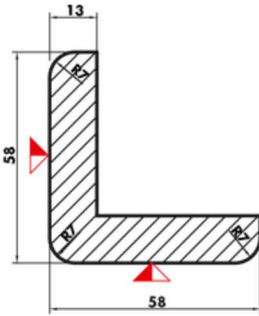
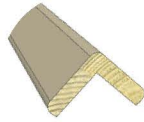

**58 x 58**

- Nordic Spruce
- Red Douglas fir

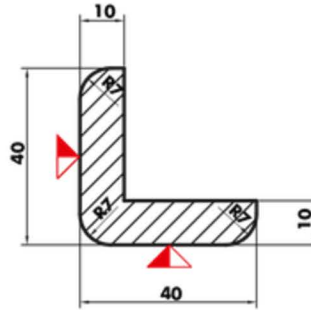

**40 x 40**

- Western Red Cedar

## COMPLEX CORNER TRIM

Compatible with Soléa II & Tabacoa II profiles

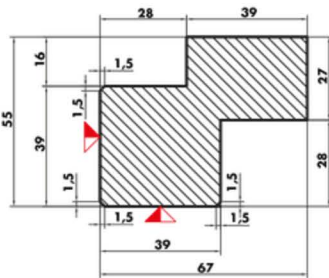
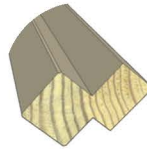

**67 x 55**

- Larch
- Red Douglas fir
- Western Red Cedar
- Ecothermo Nordic Pine

## WINDOW BOARD

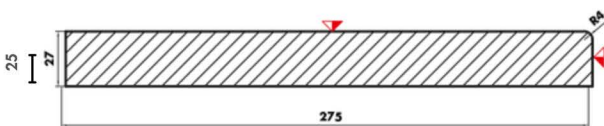

**25 x 275**

- Red Douglas fir
- Ecothermo Nordic Pine

**27 x 275\***

- Western Red Cedar
- \* 18x275 for Authentic Collection window board

## ACCESSORIES SIMULATION

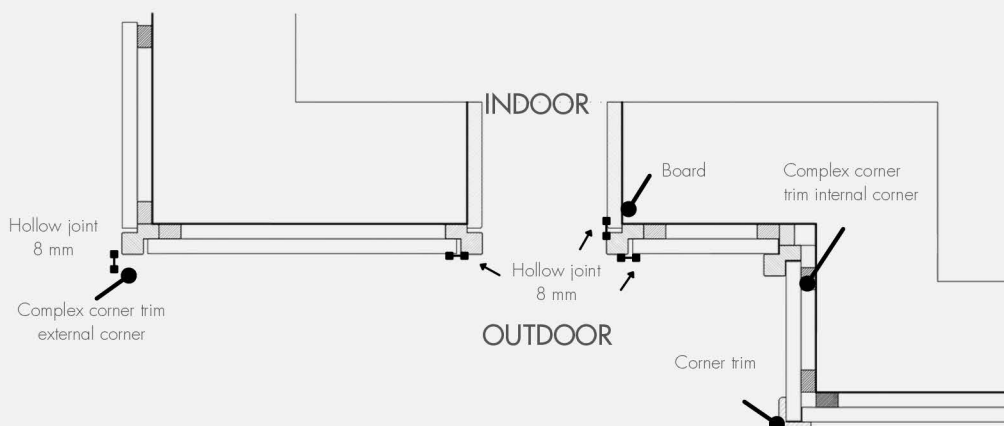



**PANELLING**

**INSTALLATION GUIDE**

Developer: Vallar Immobilier  
Contractor: LP Charpente



To ensure the products are correctly installed, the rules laid out in the French Code of practice DTU 36.2 for internal cladding should be observed.

## Installation advices

- Store the panels for a few days before installation, laid flat in well-ventilated stacks in the room where the panelling will be fitted.
- Preparation: install the panelling on a completely dry surface; avoid direct contact with the floor.
- The first panel installed serves as a guide for all subsequent ones: ensure a precise installation by checking that it is plumb when installing vertically or level when installing horizontally.
- Installation is simplified by the end grooves.
- The solid wood panels are fixed to battens spaced no more than 40 cm apart, allowing air to circulate.
- The space created in this way, known as an air gap, serves to remove moisture and vapour condensation that has passed through the wall. This air gap is essential in damp environments, such as kitchens, bathrooms and sheltered outdoor areas.

## Type and direction of installation

- Panelling boards can be installed horizontally, vertically or diagonally on wooden walls.
- There must be an air gap of at least 10 mm at all points.
- Installation in damp rooms is possible provided that adequate ventilation is ensured via windows or a mechanical ventilation system.
- The product must not come into direct contact with water.
- Fitting battens allows for the insertion of thermal or acoustic insulation and, if necessary, the concealment of cables.
- Ensure proper alignment and that the boards are driven in evenly.

## A few rules for nailing

- Nail the boards to each batten.
- The nails must be at least 3.5 times the thickness of the bottom edge of the board.
- To prevent splitting, use nails with a shank diameter of more than 3.5 mm.
- Nailing at an angle improves resistance to pulling out.

## INSTALLATION DIAGRAM FOR PANNELLING RECOMMENDED BY SIVALBP

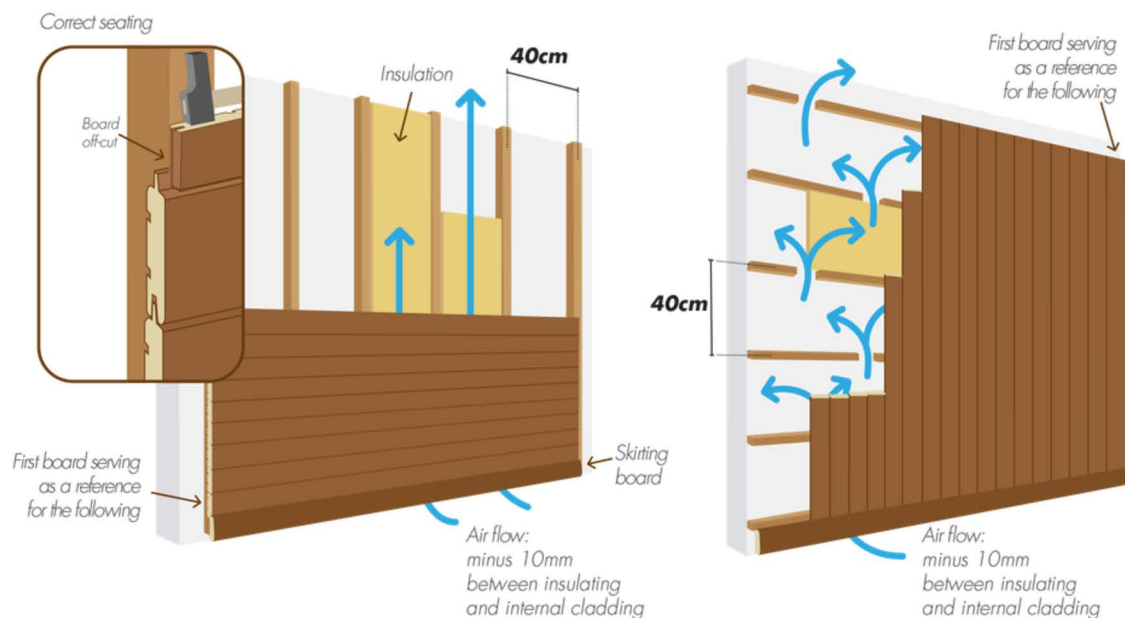

Horizontal installation

Vertical installation : mandatory double battening

# TONGUES-AND- GROOVE PROFILES (GROOVED ENDS)

## MICRO 1



Micro 1 profile available in 19x155 - 19x185 and 19x210

Installation according to DTU 36.2

## MICRO 2

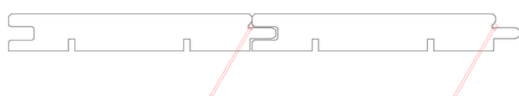

Micro 2 profile available in 20x185

Installation according to DTU 36.2

## ALPEN



Alpen profile available in 19x180 and 19x205

Installation according to DTU 36.2

# CONTACT & TECHNICAL SUPPORT

To provide you with the closest possible support for your projects, our sales team is based throughout the country. Each regional representative offers you dedicated technical expertise to guide you towards the solutions best suited to your needs and to answer any technical questions you may have.

Below you will find the contact details for your region; our team is ready to advise you and respond to all your enquiries.

**Thierry GENUIT**  
Sales Manager  
North-West France  
Tel. +33 (0)4 50 32 34 22  
Mobile : +33 (0)6 14 04 12 37  
t.genut@sivalbp.com

**Nicolas CAFFIAUX**  
Sales Manager  
North of France - Ile de France /  
Champagnes-Ardenne  
Tel. +33 (0)4 50 32 34 22  
Mobile : +33 (0)6 85 47 84 76  
n.caffiaux@sivalbp.com

**Bertrand BOMONT**  
Sales Manager  
North East France /  
Switzerland  
Tel. +33 (0)4 50 32 34 23  
Mobile : +33 (0)6 10 72 71 61  
b.bomont@sivalbp.com

**Benoit MAISONNIER**  
Sales Manager  
Center-West France  
Tel. +33 (0)4 50 05 05 04  
Mobile : +33 (0)6 07 45 51 72  
b.maisonnier@sivalbp.com

**Pascal ERHET**  
Sales Manager  
Center-East France  
Tel. +33 (0)4 50 32 34 23  
Mobile : +33 (0)6 82 68 20 02  
p.erhet@sivalbp.com

**Yves BAUDIN**  
Sales Manager  
South-West France  
Spain / Portugal / England /  
Belgium / Luxembourg  
Tel. +33 (0)4 50 05 05 04  
Mobile : +33 (0)6 81 58 78 59  
y.baudin@sivalbp.com

**Benjamin ROUQUETTE**  
Tel. +33 (0)4 50 32 34 23  
Mobile : +33 (0)6 22 87 17 80  
e.varnier@sivalbp.com

**Tel. +33 (0)4 50 32 34 23**  
**Mobile : +33 (0)6 22 87 17 80**  
e.varnier@sivalbp.com

WITH  
SIVALBP,  
BRING  
YOUR  
PROJECTS  
TO LIFE,  
BRING  
YOUR  
HOME TO  
LIFE

1, RUE DU PETIT PESSEY  
ZA LA BALMETTE  
74230 THÔNES  
TÉL. +33 (0)4 50 32 07 18

[www.sivalbp.fr](http://www.sivalbp.fr)

**sivalbp**<sup>®</sup>  
bois, technologie & design